

D

C

B

A

Step 1

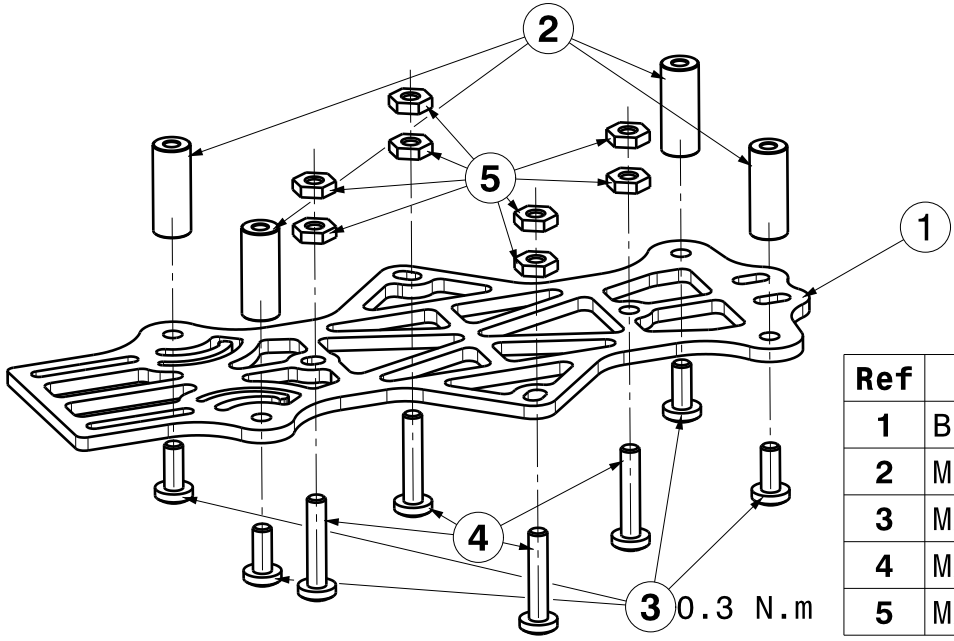

Ref	Part Name	Qty
1	Bottom Plate	1
2	M2 x 10mm standoff	4
3	M2 x 5mm Hex Screw	4
4	M2 x 10mm Screw	4
5	M2 Nylon Nut	8

Step 2

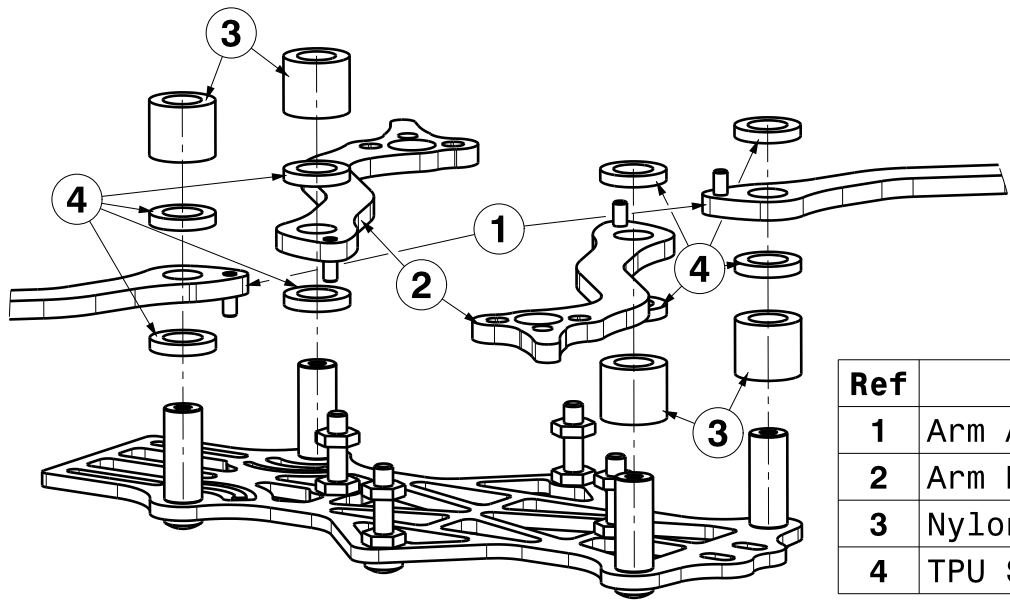

Ref	Part Name	Qty
1	Arm A	1
2	Arm B	4
3	Nylon Spacer	4
4	TPU Shim	4

Step 3

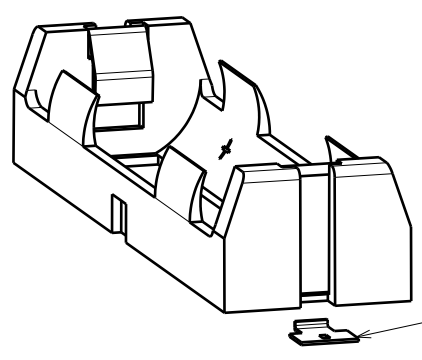

Break off the tabs by bending them back and forth with needle nose pliers
 !\ Make sure to leave a gap as to not let the metal touch the CF

SIZE A4		FRACTAL ENGINEERING		
SCALE 5:4	REVISION 0.3	DRAWING NAME Wingman Assembly Drawing	SHEET 1/2	

This drawing is our property; it can't be reproduced or communicated without our written agreement.

D

A

D

C

B

A

Step 4

4

4

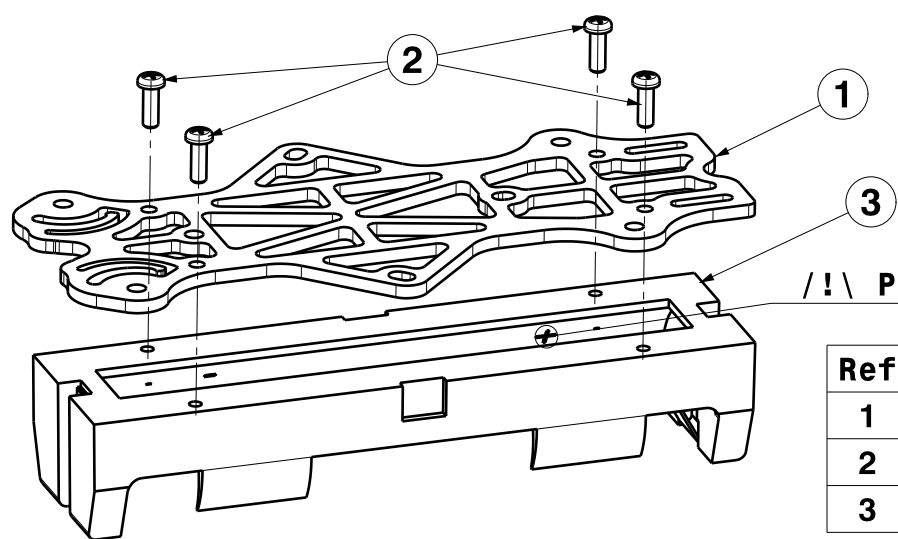

!! Positive (+) side forwards

Ref	Part Name	Qty
1	Top Plate	1
2	M1.7 Plastic Screw	4
3	Battery holder	1

3

3

Step 5

2

2

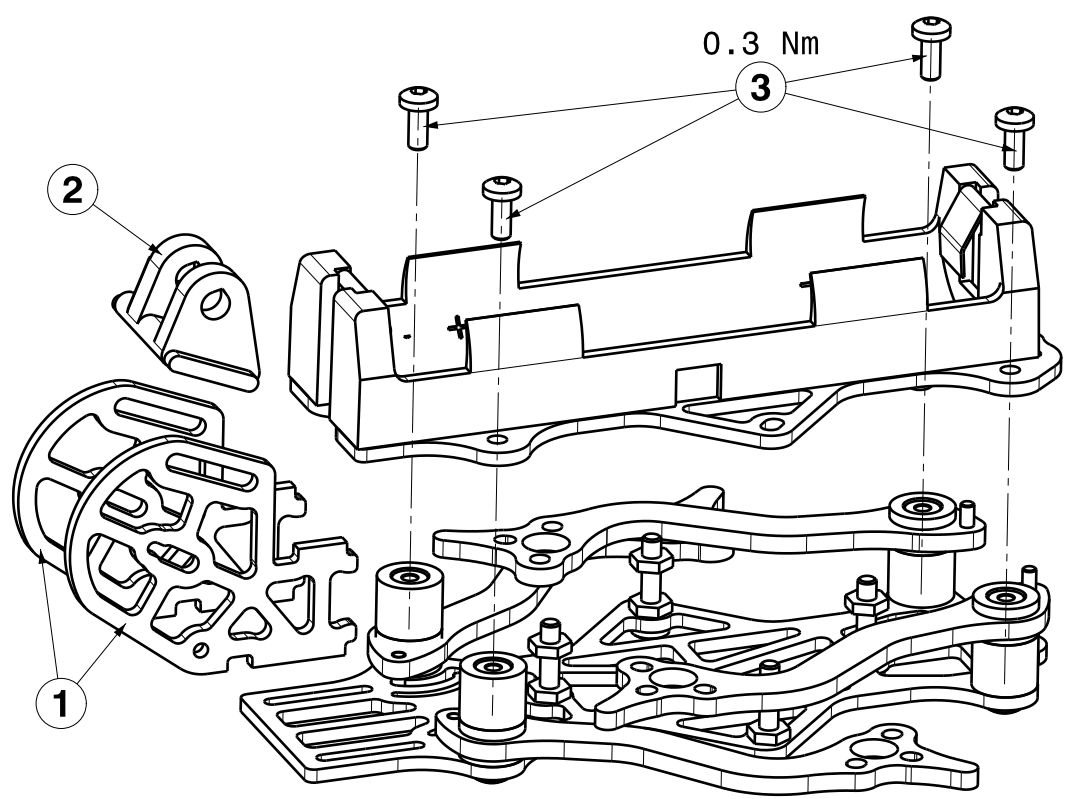

Tip:
The arms should be snug enough to hold position by friction. If too loose, use the included black TPU trim shims.

Ref	Part Name	Qty
1	Front Plate	2
2	TPU HD Cam Holder	1
3	M2 x 5mm Hex Screw	4

!! When routing the motor wires, make sure to allow extra slack for the folding action, as well as clearing the pinch points.
I recommend routing out and around the hinges (needs ~80mm wires)

1

1

SIZE A4		FRACTAL ENGINEERING		
SCALE 5:4	REVISION 0.3	DRAWING NAME Wingman Assembly Drawing	SHEET 2/2	

D

A